

THE CORPORATION OF THE MUNICIPALITY OF GREENSTONE

BY-LAW 09-48

Being a By-law to provide for the collection and disposal of waste in the Municipality of Greenstone, and to repeal By-law 04-41

WHEREAS the *Municipal Act*, 2001, S.O. c. 25 as amended, Section 8, confers broad authority on a municipality to enable the municipality to govern its affairs as it considers appropriate and to enhance the municipality's ability to respond to municipal issues;

AND WHEREAS Section 10 of the Act, authorizes municipalities to pass by-laws respecting any service or thing that the Municipality considers necessary or desirable for the public;

AND WHEREAS the Corporation of the Municipality of Greenstone deems it necessary to establish and maintain a system for the collection, removal and disposal of waste;

NOW THEREFORE THE CORPORATION OF THE MUNICIPALITY OF GREENSTONE ENACTS AS FOLLOWS:

PART I – SHORT TITLE

1. This By-law may be cited as "The Garbage By-law."

PART II – PURPOSE

2. To establish and maintain a system for the collection, removal and disposal of collectible waste within the Municipality of Greenstone.

PART III - APPLICATION

3. This By-law applies to collectible waste only. Non-collectible waste will not be collected

PART IV – DEFINITIONS

4. In this By-Law,
 - a. "**approved structure**" means any building attached or detached, which has been specifically approved by the By-Law Enforcement Officer or his authorized representative and used by commercial and institutional establishments and multiple dwellings; having hinged, tight fitting doors, which shall be kept closed at all times in order to keep flies and animals out and odors from escaping; be of acceptable appearance and painted to the satisfaction of the Director, and kept in a clean and sanitary condition and used for the storage of garbage and refuse until it is collected. No snow is to be piled against the opening of these structures.
 - b. "**collectible waste**" means and includes solid waste as distinguished from liquid waste, sewage and gas waste, smoke and industrial fumes and shall include animal and vegetable waste resulting from the handling, preparation, cooking and serving of food; market refuse and

waste from the handling, storage and sale of produce; both combustible and non-combustible waste consisting of tin cans, metal, mineral matter, glass, crockery, dust, paper, rags, cartons, boxes, leather, tree branches, grass cuttings and yard trimmings.

- c. **“acceptable commercial container”** means a “Shanahan” metal commercial bin; or an acceptable garbage box, or an approved structure. Acceptable commercial containers shall be placed on private property in a location satisfactory to the Director or be placed on any street or public property only with the express written permission of the Director, and shall be accessible at all times, and kept free and clear of ice and snow.
- d. **“acceptable garbage box”** means a container constructed of metal or pressure treated lumber and/or plywood meeting the design criteria approved by the Director; having hinged, tight fitting doors, which shall be kept closed at all times in order to keep flies and animals out and odors from escaping; be of acceptable appearance and painted to the satisfaction of the Director; kept in a clean and sanitary condition, and used for the storage of garbage and refuse until it is collected (Schedule ‘A’ attached.)
- e. **“acceptable garbage can”** means a metal or plastic container made of durable rust-proof material capable of withstanding freezing temperatures; having a tight fitting, easily removable lid which shall be in position at all times; having a tapered larger top than at the bottom; equipped with suitable handles for lifting, carrying and dumping; having a maximum capacity of not more than 40 gallons (175 liters) and a minimum capacity of not less than 10 gallons; with a filled weight not to exceed 50 pounds/23 kg, and used for the storage of garbage and refuse until it is collected.
- f. **“disabled citizen”** means a householder whose physical disability makes it extremely difficult or impossible to move their garbage to the roadside.
- g. **“Director”** means the Director of Public Services of the Municipality of Greenstone or his designate.
- h. **“householder”** means occupant, lessee, tenant, owner or any person in charge of or occupying any dwelling, business, commercial or institutional building or other premises or any portion thereof.
- i. **“multiple dwellings”** means apartment buildings, hotels, rooming houses or any separate building designed to contain 4 or more dwelling units.
- j. **“Municipality”** means The Municipality of Greenstone.
- k. **“non-collectible waste”** means and includes solid waste resulting from industrial processes, manufacturing operations, commercial food processing plants, liquid waste, materials from building construction or demolition, boulders, earth fill, explosive or combustible material, toxic and pathological waste, hay, straw, manure or night soil and automobiles.
- l. **“proper container”** means an acceptable container used for the collection, removal and disposal of collectible waste that meets the requirements contained herein.
- m. **“Senior citizen”** means a householder 65 years of age or older.

- n. “**street**” means any public highway, road, street, lane, alley, mall, square, place, thoroughfare or way within the limits of the Municipality of Greenstone.

PART V – PROPER CONTAINERS

5. Only containers meeting the requirements contained herein shall be considered proper containers for the purpose of this By-law.

a. **Residential** (other than Seniors or Disabled)

Only acceptable garbage cans shall be considered proper containers.

Residential garbage boxes concealing garbage are permitted on private property; however, residents are to place their garbage in acceptable garbage cans on the day of regular collection, and place their garbage for collection in accordance with the provisions set out in this By-law.

With the exception of sections 5.b. and 5.c., garbage will not be collected from residential garbage boxes.

b. **Residential** (Seniors)

Garbage will be collected from acceptable garbage boxes owned by Senior citizens who are registered as such with the Municipality, when the boxes are located at roadside.

Only acceptable garbage cans and acceptable garbage boxes shall be considered proper containers.

c. **Residential** (Disabled)

Garbage will be collected from proper containers on private property for disabled citizens who are registered as such with the Municipality, and who are unable to bring their garbage to roadside.

Only acceptable garbage cans and acceptable garbage boxes shall be considered proper containers.

Such containers shall be placed in a location satisfactory to the Director, be accessible at all times, and kept free and clear of ice and snow.

d. **Multiple Dwellings, Commercial & Institutional Establishments**

Only acceptable garbage cans and/or acceptable commercial containers shall be considered proper containers.

6. Fridges and freezers are not considered proper containers.

PART VI – GENERAL

7. All vegetable or animal waste resulting from the handling, preparation, cooking and serving of foods and all other offensive materials shall be strained, securely wrapped and placed in proper containers.
8. Wooden boxes, crates, branches and yard trimmings shall be securely tied in bundles not exceeding 3 feet, 6 inches or 24 inches in diameter and not weighing more than 50 pounds.

9. Newspapers, magazines and cardboard cartons shall be securely tied in compact bundles weighing not more than 50 pounds.
10. Householders shall keep their containers clean and shall regularly disinfect them.
11. Every householder shall provide and maintain in good condition a sufficient number of proper containers for collectible waste.
12. No person shall pick over, disturb, remove or scatter materials placed out for collection or obstruct collection employees in the lawful execution of their duties.
13. No employee shall be required to enter into any private property or enter any building except to gain access to approved containers for the purpose of removing collectible waste.
14. Every householder shall place their contained garbage at roadside by 7:00 a.m. on the day of regular collection.
15. The Municipality of Greenstone garbage collection system is a "roadside collection service" for collection at ground level and garbage shall be placed for collection in accordance with the following:
 - a) **roads with concrete curbs:** garbage to be placed directly behind the curb,
 - b) **roads with concrete sidewalks tightly abutting the curb:** garbage to be placed directly behind the sidewalk on property owner's side,
 - c) **roads with boulevards between sidewalks and curbs:** garbage to be placed directly on the boulevard behind the curb,
 - d) **roads with asphalt gutter and asphalt shoulder:** garbage to be placed on edge of asphalt shoulder,
 - e) **roads with gravel road shoulder:** garbage to be placed directly on road shoulder.
16. Commercial and industrial establishments must break down all their boxes or pack the smaller boxes into the larger ones. They are the only ones allowed to have locked containers or structures.
17. Cleanup of all litter resulting from the methods of setting out the collectible waste by the householder shall be the responsibility of the householder.
18. All garbage must be bagged and placed in proper containers (i.e. no cardboard boxes).
19. Sawdust must be bagged in garbage bags and placed in proper containers.

PART VII – PENALTY

20. Any person convicted of a breach of any of the terms of this By-Law shall forfeit and pay at the discretion of the convicting Judge, a penalty not exceeding the sum of **ONE THOUSAND (\$1,000.00) DOLLARS**, exclusive of costs, for each offence, such penalty and costs to be

recoverable under the provisions of The Provincial Offences Act, as provided by The Municipal Act.

21. By-law 04-41 is hereby repealed.
22. This By-Law shall come into force and take effect on January 1, 2010.

PASSED and **ENACTED** this 23rd day of November 2009.

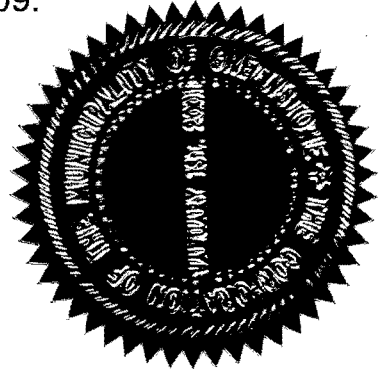

A handwritten signature in black ink, appearing to read "Michael Power".

Michael Power, Mayor

Deborah Stevens

Deborah Stevens, Clerk

Schedule 'A'
to By-law 09-48

SPECIFICATIONS
for an
ACCEPTABLE GARBAGE BOX

- Unit to be a minimum of 2 ft. off the ground
- Unit to be of sufficient size to accommodate all waste generated
- Unit to be anchored to the ground so as not to be overturned by the wind
- Doors on unit to be hinged and tight fitting
- Doors on unit to be outswing and able to open 180 degrees
- Doors on unit to be kept closed at all times with appropriate hardware
- There are to be no nails, bolts or screws protruding so as to injure anyone
- Construction to be of metal or pressure treated lumber and/or plywood
- Wafer board is not acceptable
- Unit to be kept in a clean and sanitary condition at all times.

Design 1

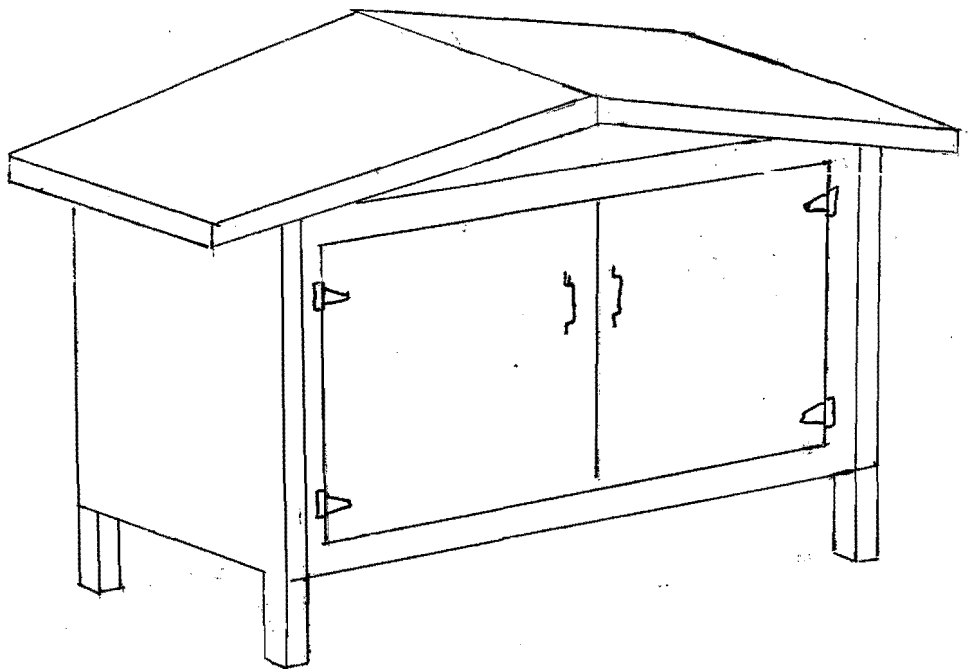

Design 2

